

**12b**

SAILSetc Catalogue Number

Fitting Description    **ball raced gooseneck/compression strut – concentric axis**Applications    **14 mm round mast for SAILSetc Marblehead & Ten Rater**Drawing Code    **Product Information PI 12b**    *copyright SAILSetc 2013*

Contents	Qty	Item
gooseneck/compression strut unit	1	
No 4 x 13 mm pan head screw	1	
No 2 x 9 mm self tapping screw	1	
1.8 mm diameter drill	1	

**1** The gooseneck is fixed to the mast by drilling, using a 2.5 mm drill, through the hole provided in the upper bearing. Add the No 4 self tapping screw and do not over-tighten. The mast should be reinforced internally with 12 mm diameter carbon tube in this region.

**2** Slide the gooseneck body onto the mast so that the upper bearing is housed properly in the upper bearing support.

**3** Add the lower bearing support ensuring that it engages properly with the bearing.

**4** Wrap some self adhesive tape around the mast tube to keep the lower bearing housing from slipping down the mast.

**5** The boom of 14 mm diameter carbon tube is pushed into the boom end. Drill with the 1.8 mm diameter drill and use the No 2 self tapping screw to lock the boom in place.

6-7 spare

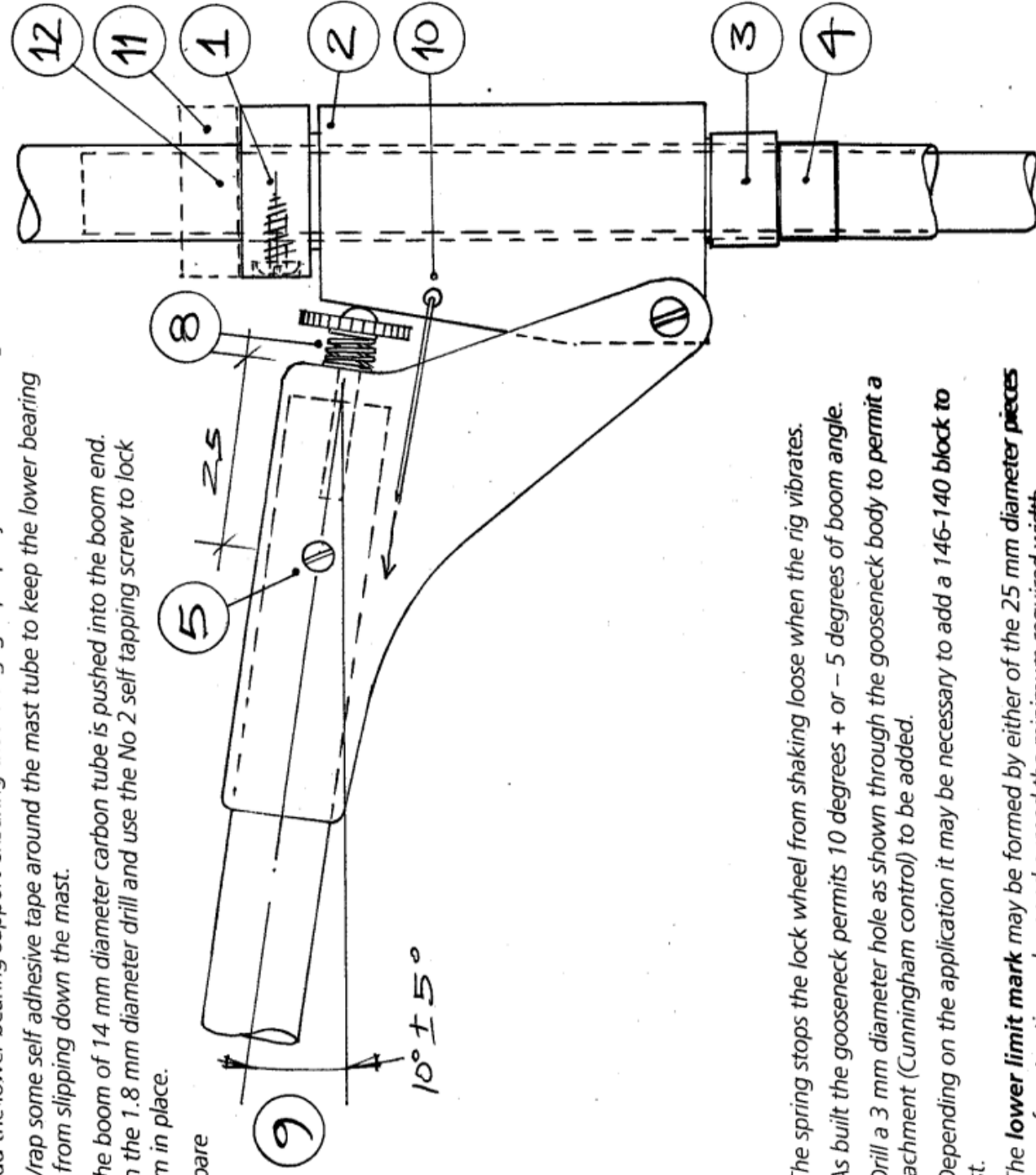

**8** The spring stops the lock wheel from shaking loose when the rig vibrates.

**9** As built the gooseneck permits 10 degrees + or - 5 degrees of boom angle.

**10** Drill a 3 mm diameter hole as shown through the gooseneck body to permit a tack attachment (Cunningham control) to be added.

**11** Depending on the application it may be necessary to add a 146-140 block to the mast.

**12** The lower limit mark may be formed by either of the 25 mm diameter pieces as they are of contrasting colour and exceed the minimum required width.